

AERIAL DEVICE

Terex® Hi-Ranger Aerial Devices are known throughout the industry. They come with a long history featuring quality and innovative design.

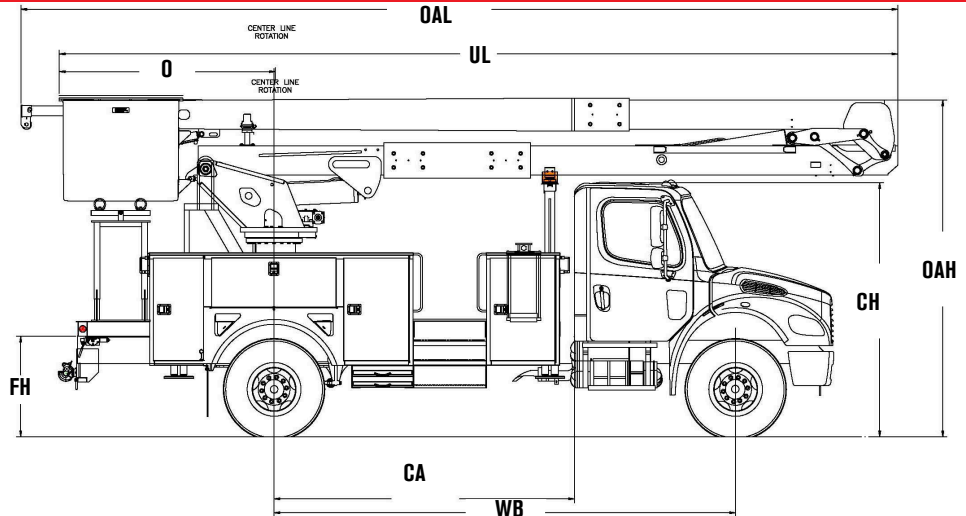

Measurements	Optima TCX50	Optima TCX55	Optima TCX60
Typical Frame Height (FH)	40 in. (101.6 cm)	40 in. (101.6 cm)	40 in. (101.6 cm)
Typical Cab Height (CH)	107 in. (272 cm)	107 in. (272 cm)	107 in. (272 cm)
Offset (O)	88 in. (223.5 cm)	88 in. (223.5 cm)	88 in. (223.5 cm)
Overall Height (OAH)	11' 11" (3.6 m)	11' 11" (3.6 m)	11' 11" (3.6 m)
Overall Length (OAL)	26' 8" (8.1 m)	29' 2" (8.9 m)	31' 8" (9.7 m)
Unit Length (UL)	25' 5" (7.75 m)	27' 11" (8.6 m)	30' 5" (9.2 m)
Center of Rotation (H)	-	-	-
Cab to Axle (CA)	120 in. (304.8 cm)	120 in. (304.8 cm)	120 in. (304.8 cm)
Wheel Base (WB)	187 in. (475 cm)	187 in. (475 cm)	187 in. (475 cm)
Front Axle (FA)	12,000 lb. (5,443 kg)	12,000 lb. (5,443 kg)	12,000 lb. (5,443 kg)
Rear Axle (RA)	21,000 lb. (9,525 kg)	21,000 lb. (9,525 kg)	21,000 lb. (9,525 kg)
Gross Vehicle Weight Rating (GVWR)	31,000 lb. (14,061 kg)	31,000 lb. (14,061 kg)	33,000 lb. (14,969 kg)
Recommended Weight for Stability	20,000 lb. (9,525 kg)	20,000 lb. (9,525 kg)	22,000 lb. (9,979 kg)
Frame Section Modulus	18.0 in ³	18.0 in ³	18.0 in ³
Frame Yield Strength	50,000 psi	50,000 psi	50,000 psi
Frame RBM	900,000 in-lbs	900,000 in-lbs	900,000 in-lbs

OPTIMA TCX SERIES

Hi-Ranger Non-Overcenter Material Handling Aerial Device

STANDARD EQUIPMENT

- Side-Mount 24" x 48" x 42" Two-Person Platform
- Platform Capacity up to 700 lb (318 kg)
- Control-Plus "3-D" Single Stick Control At Platform
- Hydraulic Platform Rotators (105° Side Mt)
- Simplified Compact, Hydraulic Extending Jib
- Safety Harness with Attached Lanyard
- Continuous Unrestricted Worm Gear Rotation
- Category "C" Rating Per ANSI A92.2
- Rectangular, Bi-Axial Epoxy Resin, Filament Wound Fiberglass Booms
- Individual Lever Lower Controls
- Non-Compensated Boom, Full-Pressure Open-Centered Hydraulic System
- Automatic Throttle
- Hydraulic Platform Tilt At Upper and Lower controls
- Hydraulic Lower, Mechanical Upper Platform Leveling System
- 70° of Elevation Above Horizontal
- +70° to -90° of Upper Boom Articulation
- 116° of Lower Boom Articulation
- Hydraulic Dual Tools with Flow Control
- Engine Stop /Start
- 30 Gallon Bed Mount Hydraulic Oil Reservoir
- Padded Boom Rest with Upper Boom Tie Downs
- Outrigger Interlock
- Moving Outrigger Alarm
- Truck Level Indicator

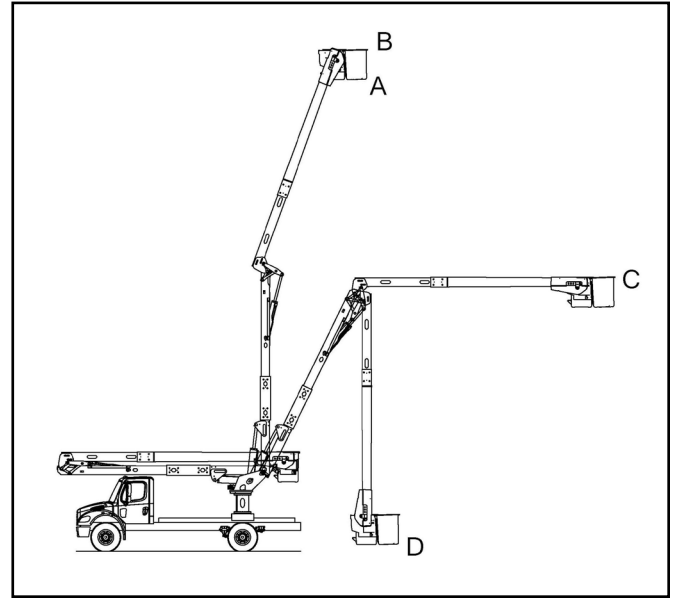

CAPACITIES & DIMENSIONAL DATA (Based on a 40 inch Frame Height)

OPTIMA Model	A	B	C	D
	Bottom of Platform	Working Height	Side Reach	Bottom Platform to Ground
TCX50	50 ft (15.2 m)	55.0 ft (16.8 m)	39.3 ft (12.0 m)	1.6 ft (0.5 m)
TCX55	55.0 ft (16.8 m)	60.0 ft (18.3 m)	42.8 ft (13.0 m)	1.3 ft (0.4 m)
TCX60	60.0 ft (18.3 m)	65.0 ft (19.8 m)	46.4 ft (14.1 m)	1.1 ft (.33 m)

OPTIONAL EQUIPMENT

- Optional 800 lb. (363 kg) Platform Capacity (Available on 50' & 55' Only)
- 24" x 30" x 42" One-Person Side Platform
- Various Platform Covers
- Liners with or Without Steps
- 24" Platform Lifter (90° Side Mt)
- Jib Options (Side Mount Only)
 - Hydraulic Articulating Jib/Winch, Extend Underload Side Mount 2000 lbs.(907 kg)
 - Single Wire / 46 Kv Insulated
- Single Wire / 15 Kv Insulated
- Single Line Lifter / Multi-Phase Attachments
- Manual Two-Speed Throttle
- Category "B" Rating Per ANSI A92.2
- Compensated Boom Design
 - Closed-Center, Power Assist Control System
 - 50 Gallon Bed Mount Hydraulic Oil Reservoir
- Lower Boom Lifting Eye
- Automatic Upper Boom Latch
- Hydraulic Oil Cooler
- Auxiliary Power
- Auxiliary Let Down System
- Boom Overstow Protection
- Boom Stow Interlock
- Boom Storage Warning Light
- Outrigger Sag Light
- Various Types of Outriggers
- Truck Grounding Cable & Clamp