



TEREX®

GENERAL SERIES

DIGGER DERRICK

Terex® Telelect Digger Derricks are known throughout the industry. They come with a long history featuring quality and innovative design.

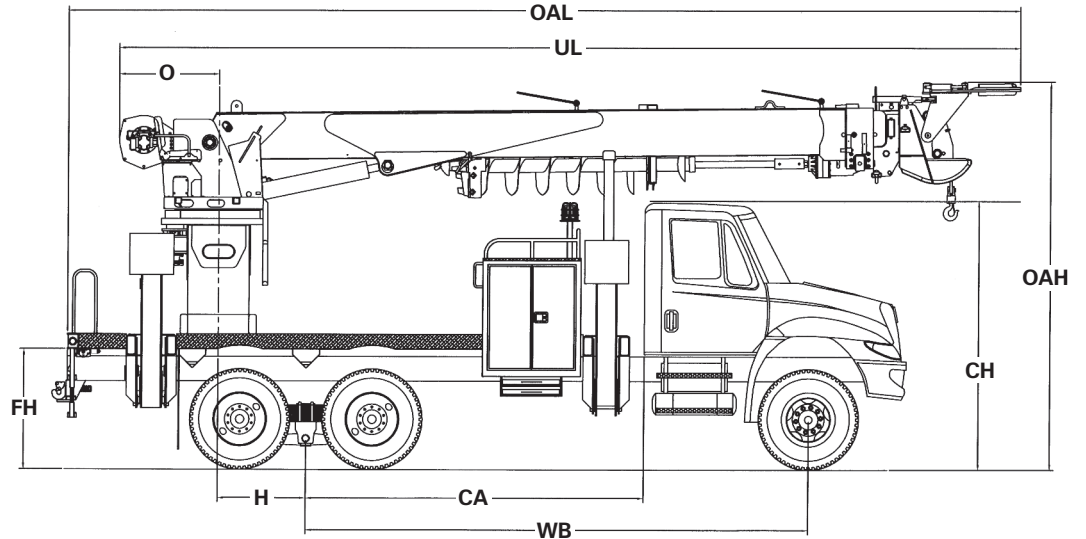

Measurements	General 65	General 80	General 95
	ORA	ORA	ORA
Typical Frame Height (FH)	45 in. (114.3 cm)	45 in. (114.3 cm)	45 in. (114.3 cm)
Typical Cab Height (CH)	117 in. (297.2 cm)	117 in. (297.2 cm)	117 in. (297.2 cm)
Offset (O)	40.0 in. (101.6 cm)	46.3 in. (117.6 cm)	40.0 in. (101.6 cm)
Overall Height (OAH)	13' 2" (4.0 m)	13' 3" (4.0 m)	12' 7" (3.8 m)
Overall Length (OAL)	32' 2" (9.9 m)	33' 0" (10.1 m)	36' 4" (11.1 m)
Unit Length (UL)	30' 5" (9.3 m)	31' 9" (9.7 m)	34' 5" (10.5 m)
Center of Rotation (H)	36 in. (91.4 cm)	36 in. (91.4 cm)	36 in. (91.4 cm)
Cab to Axle (CA)	138 in. (350.5 cm)	138 in. (350.5 cm)	156 in. (396 cm)
Wheel Base (WB)	213 in. (541 cm)	213 in. (541 cm)	228 in. (579.1 cm)
Front Axle (GAWR)	16,000 lb. (7,258 kg)	16,000 lb. (7,258 kg)	16,000 lb. (7,258 kg)
Rear Axle (GAWR)	34,000 lb. (15,422 kg)	34,000 lb. (15,422 kg)	34,000 lb. (15,422 kg)
Gross Vehicle Weight Rating	50,000 lb. (22,680 kg)	50,000 lb. (22,680 kg)	50,000 lb. (22,680 kg)
Recommended Weight For Stability (GVWR)	40,000 lb. (18,144 kg)	45,000 lb. (20,412 kg)	42,000 lb. (19,051 kg)
Frame Section Modulus	24.0 in ³	24.0 in ³	24.0 in ³
Frame Yield Strength	80,000 psi	80,000 psi	80,000 psi
Frame RBM	1,920,000 in-lbs	1,920,000 in-lbs	1,920,000 in-lbs



TEREX®

500 Oakwood Drive
PO BOX 1150
Watertown, SD 57201-6150
USA

Phone: (605) 882-4000
Facsimile: (605) 882-1842
www.terexutilities.com
E-mail: utilities.info@terex.com

Distributed By:

STANDARD EQUIPMENT

- 90 Degrees of Boom Travel (+80 to -10)
- Dual Lift Cylinders
- Self-Aligning Swivel Ball Bushings
- Rectangular, Bi-Axial Epoxy Resin, Filament Wound Fiberglass Booms
- Box Fabricated Steel Lower Boom and Intermediate
- Hydraulic Boom Extension Intermediate & Upper
- Full Pressure Hydraulic Controls
- Full Pressure, Open-Center Hydraulic System
- 70 Gallon Hydraulic Oil Reservoir
- Custom Made Zoned Load Chart
- Continuous Unrestricted Rotation
- 15,000 lb. Planetary Turntable Winch
- Meets or Exceeds ANSI A10.31
- Planetary Parking Brake Rotation
- Right-Hand Command Post Controls
- Engine Stop/Start at Lower Controls
- Boom Angle Indicator
- Outrigger Interlock
- Moving Outrigger Alarm
- Truck Level Indicator

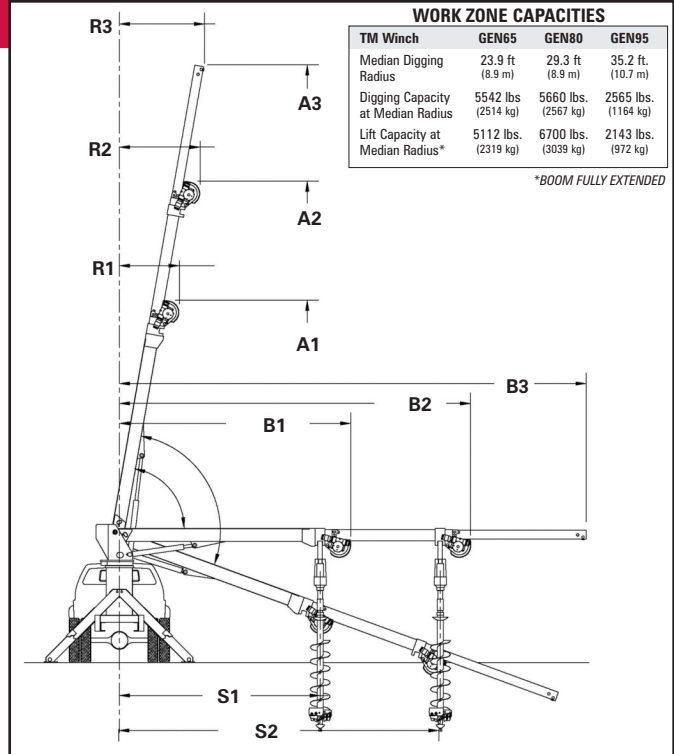

CAPACITIES & DIMENSIONAL DATA (Based on a 40 Inch Frame Height)

Model	Maximum Capacity	Capacity @ 10 ft. Radius	Sheave Height			Load Radius			Horizontal Reach			Digging Radius	
			A1	A2	A3	R1	R2	R3	B1	B2	B3	S1	S2
GENERAL '65	42,110 lb (19,101 kg)	21,010 lb (9,530 kg)	35.5 ft (10.8 m)	50.3 ft (15.3 m)	65.1 ft (19.8 m)	4.4 ft (1.3 m)	7.0 ft (2.1 m)	9.7 ft (3.0 m)	25.1 ft (7.7 m)	40.1 ft (12.2 m)	55.1 ft (16.8 m)	21.4 ft (6.5 m)	36.4 ft (11.1 m)
**GENERAL '80	48,790 lb (22,131 kg)	24,320 lb (11,031 kg)	36.4 ft (11.1 m)	51.2 ft (15.6 m)	*80.3 ft (24.5 m)	4.9 ft (1.5 m)	7.5 ft (2.3 m)	*12.6 ft (3.8 m)	25.2 ft (7.7 m)	40.2 ft (12.3 m)	*69.8 ft (21.3 m)	21.9 ft (6.7 m)	36.9 ft (11.2 m)
**GENERAL '95	35,650 lb (16,171 kg)	19,830 lb (8,995 kg)	39.5 ft (12.0 m)	58.2 ft (17.7 m)	*95.6 ft (29.1 m)	5.1 ft (1.6 m)	8.4 ft (2.6 m)	*15.5 ft (4.7 m)	29.1 ft (8.9 m)	48.1 ft (14.7 m)	*86.1 ft (26.2 m)	25.4 ft (7.7 m)	39.4 ft (13.5 m)

*Indicates Dimensions which apply to 4 Section Boom

**3rd and 4th Section are Steel (Optional Fiberglass 4th Section)

OPTIONAL EQUIPMENT

- Various Digger/Augers
 - Auger Storage Left Side (Typical)
 - Auger Storage Right Side (Subject to Configuration)
- Fiberglass Personnel Platform
 - Liners With or Without Steps
- Hand Rack Controls
- Various Types of Controls
- Radio Remote Controls
- Single Stick "T" Control
- Engine Stop/Start and Throttle Advance at Top Controls
- Various Types of Throttle Advance at Lower Controls
- Hydraulic Overload Protection (HOP)
- Material Handling Jibs
- Transferable Pole Flanges
- Various Sizes of Pole Guides
- Pole Guide Interlock
- Planetary Slip Brake Rotation
- Hydraulic Tool Outlets
- Pole Puller
- Multi-Part Line Components
- Boom Storage Warning Light
- Outrigger Sag Light
- Various Types of Outriggers
- Truck Grounding Cable & Clamp

Effective Date: November 2015. Product specifications and prices are subject to change without notice or obligation. The photographs and/or drawings in this document are for illustrative purposes only. Refer to the appropriate Operator's Manual for instructions on the proper use of this equipment. Failure to follow the appropriate Operator's Manual when using our equipment or to otherwise act irresponsibly may result in serious injury or death. The only warranty applicable to our equipment is the standard written warranty applicable to the particular product and sale and Terex makes no other warranty, express or implied. Products and services listed may be trademarks, service marks or trade-names of Terex Corporation and/or its subsidiaries in the USA and other countries. All rights are reserved. Terex® is a registered trademark of Terex Corporation in the USA and many other countries. Copyright 2015 Terex Corporation.