

## AERIAL DEVICE

Terex® Hi-Ranger Aerial Devices are known throughout the industry. They come with a long history featuring quality and innovative design.

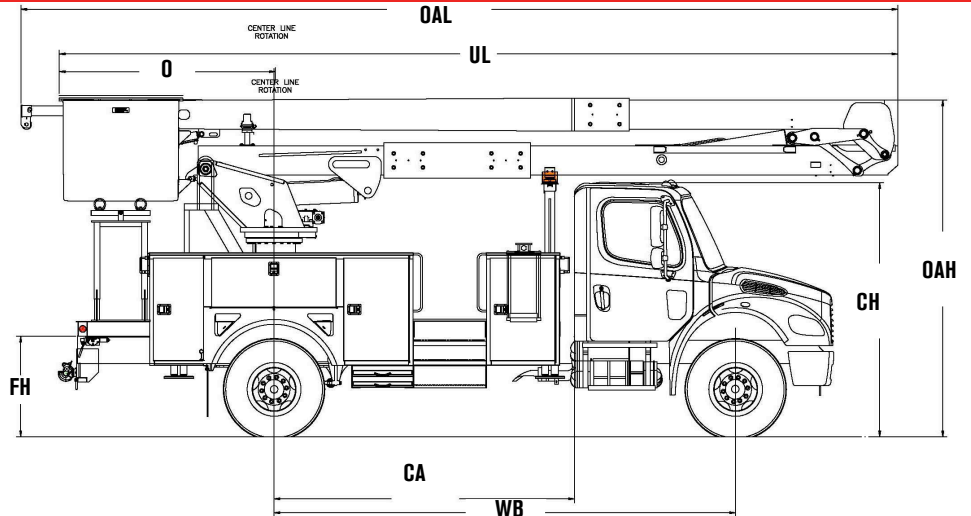

Measurements	Optima HR50	Optima HR55
Typical Frame Height (FH)	40 in. (101.6 cm)	40 in. (101.6 cm)
Typical Cab Height (CH)	107 in. (272 cm)	107 in. (272 cm)
Offset (O)	88 in. (223.5 cm)	88 in. (223.5 cm)
Overall Height (OAH)	11' 11" (3.6 m)	11' 11" (3.6 m)
Overall Length (OAL)	26' 8" (7.8 m)	29' 2" (8.9 m)
Unit Length (UL)	25' 5" (7.75 m)	27' 11" (8.6 m)
Center of Rotation (H)	-	-
Cab to Axle (CA)	102 in. (259 cm)	108 in. (274.3 cm)
Wheel Base (WB)	169 in. (429 cm)	175 in. (444.5 cm)
Front Axle (FA)	10,500 lb. (4,763 kg)	10,500 lb. (4,763 kg)
Rear Axle (RA)	19,000 lb. (8,618 kg)	19,000 lb. (8,618 kg)
Gross Vehicle Weight Rating (GVWR)	29,500 lb. (13,381 kg)	29,500 lb. (13,381 kg)
Recommended Weight for Stability	16,000 lb. (7,256 kg)	17,000 lb. (7,711 kg)
Frame Section Modulus	18.0 in <sup>3</sup>	18.0 in <sup>3</sup>
Frame Yield Strength	50,000 psi	50,000 psi
Frame RBM	900,000 in-lbs	900,000 in-lbs

# OPTIMA HR SERIES

## Hi-Ranger Overcenter Material Handling Aerial Device

### STANDARD EQUIPMENT

- Side-Mount 24" x 48" x 42" Two-Person Platform
- Platform Capacity up to 700 lb (318 kg)
- Control-Plus "3-D" Single Stick Control At Platform
- Hydraulic Platform Rotators (105° Side Mt)
- Simplified Compact, Hydraulic Extending Jib
- Safety Harness with Attached Lanyard
- Continuous Unrestricted Worm Gear Rotation
- Category "C" Rating Per ANSI A92.2
- Rectangular, Bi-Axial Epoxy Resin, Filament Wound Fiberglass Booms
- Individual Lever Lower Controls
- Automatic Throttle
- Hydraulic Platform Tilt At Upper and Lower controls
- Hydraulic Lower, Mechanical Upper Platform Leveling System
- 193° of Upper Boom Articulation
- 116° of Lower Boom Articulation
- Full Pressure, Open-Center Hydraulic System
- Hydraulic Dual Tools with Flow Control
- Engine Stop /Start
- 30 Gallon Bed Mount Hydraulic Oil Reservoir
- Padded Boom Rest with Upper Boom Tie Downs
- Outrigger Interlock
- Moving Outrigger Alarm
- Truck Level Indicator

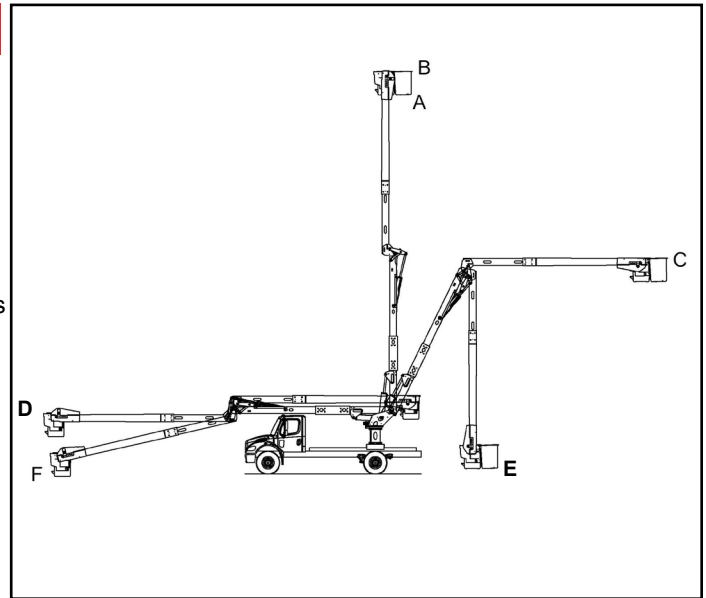

### CAPACITIES & DIMENSIONAL DATA (Based on a 40 inch Frame Height)

OPTIMA Model	A	B	C	D	E	F
	Bottom of Platform	Working Height	Non-Overcenter Side Reach at 116° LB Ground Access	Overcenter Side Reach	Bottom of Platform to Ground at 116° with Ground Access	Bottom Platform to Ground
HR50	50.0 ft (15.2 m)	55.0 ft (16.8 m)	39.3 ft (12.0 m)	43.2 ft (13.2 m)	1.6 ft (48 cm)	7 in. (17.8 cm)
HR55	55.0 ft (16.8 m)	60.0 ft (18.3 m)	42.8 ft (13.0 m)	48.2 ft (14.7 m)	1.3 ft (38 cm)	-1 in. (-2.54 cm)

### OPTIONAL EQUIPMENT

- 24" x 30" x 42" One-Person Side Platform
- Various Platform Covers
- Liners with or Without Steps
- 24" Platform Lifter (90° Side Mount)
- Jib Options (*Side Mount Only*)
  - Hydraulic Articulating Jib/Winch, Extend Underload Side Mount 2000 lbs.(907 kg)
  - Single Wire / 46 Kv Insulated
- Single Wire / 15 Kv Insulated
- Single Line Lifter / Multi-Phase Attachments
- Manual Two-Speed Throttle
- Category "B" Rating Per ANSI A92.2
- Lower Boom Lifting Eye
- Automatic Upper Boom Latch
- Hydraulic Oil Cooler
- Auxiliary Power
- Auxiliary Let Down System
- Boom Overstow Protection
- Boom Stow Interlock
- Boom Storage Warning Light
- Outrigger Sag Light
- Various Types of Outriggers
- Truck Grounding Cable & Clamp