

ACHIEVER
TC-55 TRACKED AERIAL

The Ultimate 58 ft Working Height, Low Ground Pressure Tracked Aerial

Level off to within 5° on 12° slopes
Haul on a 15 Ton Trailer



UTV Achiever Carrier with a Terex Optima TC-55 High Ranger



UTV
International

DIMENSIONS / WEIGHT	
Overall Length	360"
Overall Width	101"
Overall Height	118"
Ground Clearance	16"
Weight & Payload	
- Basic Vehicle	20,600 lbs (Basic vehicle with boom)
- GVW	24,000 lbs
Deck Area	87" x 87" (approximately)
PERFORMANCE DATA	
Maximum speed	8 mph (loaded)
Inside turning radius	0 ft.
Climbing Ability	
- Uphill	40° (84%)
- Side-hill	15° (27%)
Ground Pressure	2.83 PSI with boom, typical, 3.44 PSI max load
Normal Driving Range	12 Hours (40 U.S. gallon fuel tank)
ENGINE	
Make	Deutz AG
Model	TCD 3.6 L4, 4 cylinder Turbo Charged Diesel
Horsepower	134 HP @ 2,300 RPM
Displacement	3.6 liters
DEF Tank	2.6 gals.
Fuel capacity	40 gals.
Torque	369 ft lbs. @ 1,600 RPM
FRAME / SUSPENSION	
Type	Corten Welded Tub
Axles	Independent Torsion Axles
Tires	Solid Rubber
Suspension system comes with:	
<ul style="list-style-type: none"> • 2 independent idler wheels with oil hubs & steel face seals • 8 x 20" solid wheels with grease hubs & dust cap retainers • 2 x rear drive sprockets 	
TRACKS	
Rubber 5 ply belts with 29" rubberized aluminum crosslinks	
STEERING	
Independent dual joysticks with cable control for each track	
ELECTRICAL	
Voltage	12 V
Batteries	2 x 1060 CCA
Alternator Capacity	120 Amps

OPTIONAL EQUIPMENT & ACCESSORIES	
<ul style="list-style-type: none"> • 2 Way front plow • 16,500 lb electric winch • 18,000 lb hydraulic winch • F.O.P.S. Certified Cab • Closed cab • Air Conditioning • Cold weather package • Extreme cold weather package 	<ul style="list-style-type: none"> • Ice claws for tracks • Ice cleats for outriggers • Front brush guard • Side brush guard • Rear view camera • Additional LED lights • Spark arrester • Pintle hook • 100 Hours service kit

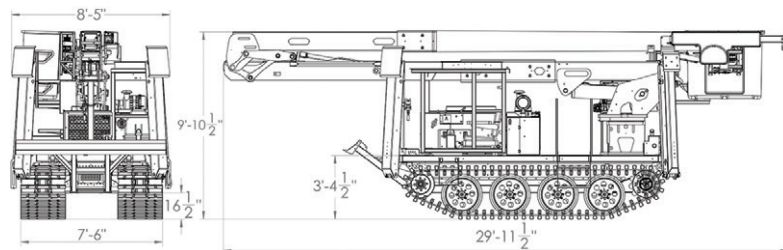

POWERTRAIN FOR HYDROSTATIC DRIVE	
Transmission	Hydrostatic, 2-speed
Parking Brakes	Multi-disc, spring applied & pressure released
Service Brakes	Positive deceleration via hydrostatic transmission
CARRIER STANDARD FEATURES	
<ul style="list-style-type: none"> • 1 Man cab 24,000 lbs R.O.P.S. certified (SAE J1040) • Vinyl seat with mechanical adjustment • 2 Front lights, 1 Rear light and 1 Strobe • Electronic engine protection system • Primary fuel filter with water separator • Operations, Service and Parts Manual • 18" x 20" front outrigger feet • 10" x 10" rear outrigger feet • 2 point seat belt • Open or closed cab • Levels on a 12° slope 	<ul style="list-style-type: none"> • Full instrumentation • Fire extinguisher • Backup alarm • Horn • Extra long 71" heavy duty front hydraulic radial outriggers • Extra long 71" super duty rear hydraulic radial outriggers • Tools outlet at the bucket and/or on deck • Haul on a 15 ton trailer
AERIAL SPECIFICATIONS	
Dimensions / Capacities	
Working Height	58'
Bottom of Basket	52' 8"
Side Reach	40'
Upper Boom Articulation	+70° to -90°
Lower Boom Articulation	116°
Stowed Travel Height	111"
Basket	24" x 48" x 42"
Material handling jib	2,000 lb

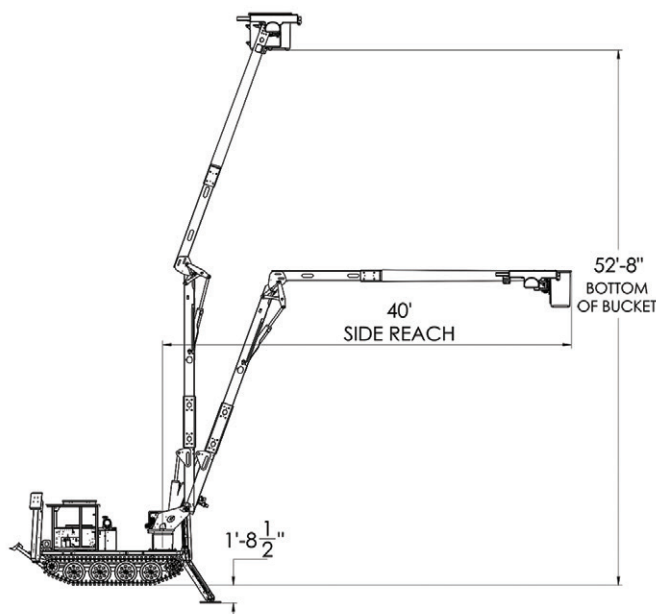

* Specifications subject to change without notice.